



High-speed IGBT Power Transistor

(Integrated FRD)

Preliminary

HKW50N65SHEE

1. Product Features:

- Ultra-low switching losses
- Benchmark efficiency in hard switching topologies
- Internal integrated fast&soft recovery anti-parallel FRD
- Maximum junction temperature 175°C
- Qualified according to JEDEC
- RoHS compliant

2. Product Applications

- Industrial Power Supplies
- Solar String Inverter
- Energy Storage Inverter
- UPS
- DC Charger for Electric Vehicles
- Welding Machines

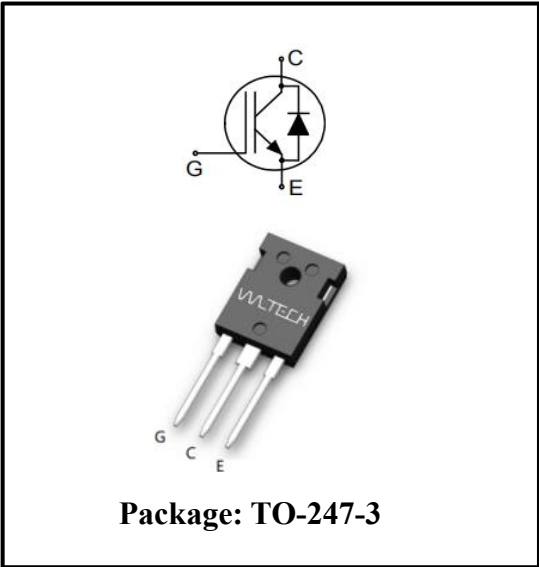

3. Typical Performance Parameters

Tab.1. Typical Performance Parameters

Type	V_{CE}	I_C	V_{CEsat} $T_{vj} = 25^\circ C$	T_{vjmax}	Marking	Package
HKW50N65SHEE	650V	50A	1.56V	175°C	HKW50N65SHEE	TO-247-3

4. Maximum Ratings

Tab.2. Maximum Ratings

Parameters	Symbol	Value	Unit
Collector-emitter voltage, $T_{vj} \geq 25^{\circ}\text{C}$	V_{CE}	650	V
DC collector current (limited by T_{vjmax})	I_C	80($T_c = 25^{\circ}\text{C}$) 50($T_c = 100^{\circ}\text{C}$)	A
Pulsed collector current (t_p limited by T_{vjmax} .)	I_{Cpuls}	200	A
Diode forward current (limited by T_{vjmax})	I_F	60 ($T_c = 100^{\circ}\text{C}$)	A
Diode pulse current (t_p limited by T_{vjmax} .)	I_{Fpuls}	200($T_c = 25^{\circ}\text{C}$)	A
Gate-emitter voltage	V_{GE}	± 20	V
Transient Gate-emitter voltage ($t_p \leq 10\mu\text{s}$, $D < 0.0100$)		± 30	V
Power dissipation	P_{tot}	405($T_c = 25^{\circ}\text{C}$) 202($T_c = 100^{\circ}\text{C}$)	W
Operating junction temperature	T_{vj}	-40 to +175	$^{\circ}\text{C}$
Storage temperature	T_{stg}	-55 to +150	$^{\circ}\text{C}$
Soldering temperature, (wave soldering 1.6mm from case for 10s)		260	$^{\circ}\text{C}$
Mounting torque (M3 screw) (Maximum of mounting processes: 3)	M	0.6	Nm

5. Thermal Properties

Tab.3. Thermal Properties

Parameters	Symbol	Max. value	Unit
IGBT thermal resistance (junction - case)	$R_{th(j-c)}$	0.37	$^{\circ}\text{C}/\text{W}$
Diode thermal resistance (junction - case)	$R_{th(j-c)}$	0.42	$^{\circ}\text{C}/\text{W}$
Thermal resistance (junction – ambient)	$R_{th(j-a)}$	40	$^{\circ}\text{C}/\text{W}$

6. Electrical Characteristics

Tab.4. Static Characteristic ($T_{vj} = 25^{\circ}\text{C}$, unless otherwise specified)

Parameters	Symbol	Conditions	Min. value	Typ. value	Max. value	Unit
Collector-emitter breakdown voltage	$V_{(BR)CES}$	$V_{GE} = 0\text{V}, I_C = 1\text{mA}$	650	-	-	V
Collector-emitter saturation voltage	V_{CEsat}	$V_{GE} = 15\text{V}, I_C = 50\text{A}$ $T_{vj} = 25^{\circ}\text{C}$ $T_{vj} = 175^{\circ}\text{C}$	- -	1.56 2.13	2.1 -	V
Diode forward voltage	V_F	$V_{GE} = 0\text{V}, I_F = 50\text{A}$ $T_{vj} = 25^{\circ}\text{C}$ $T_{vj} = 175^{\circ}\text{C}$	- -	1.47 1.23	2.2 -	V
Gate-emitter threshold voltage	$V_{GE(th)}$	$I_C = 0.5\text{mA}, V_{CE} = V_{GE}$	4.2	5.12	6.2	V
Zero gate voltage collector current	I_{CES}	$V_{CE} = 650\text{V}, V_{GE} = 0\text{V}$ $T_{vj} = 25^{\circ}\text{C}$ $T_{vj} = 175^{\circ}\text{C}$	- -	1 2000	75 -	μA
Gate-emitter leakage current	I_{GES}	$V_{CE} = 0\text{V}, V_{GE} = 20\text{V}$	-	-	100	nA
Transconductance	g_{fs}	$V_{CE} = 20\text{V}, I_C = 50\text{A}$	-	43	-	S
Internal Gate Resistance	$R_{G(int)}$	$f = 1\text{MHz}, V_{ac} = 10\text{mV}$	-	8	-	Ω

Tab.5. Dynamic Characteristic ($T_{vj} = 25^{\circ}\text{C}$, unless otherwise specified)

Parameters	Symbol	Conditions	Min. value	Typ. value	Max. value	Unit
Input capacitance	C_{ies}	$V_{CE} = 25\text{V}, V_{GE} = 0\text{V}$ $f = 1\text{MHz}$	-	1651	-	pF
Output capacitance	C_{oes}		-	210	-	
Reverse transfer capacitance	C_{res}		-	36	-	
Gate-charge	Q_g	$V_{CE} = 520\text{V}, I_C = 50\text{A},$ $V_{GE} = 15\text{V}$	-	78	-	nC

Tab.6. Switching Characteristic (Inductive load)

Parameters	Symbol	Conditions	Min. value	Typ. value	Max. value	Unit
IGBT Characteristic, at $T_{vj} = 25^{\circ}\text{C}$						
Turn-on delay time	$t_{d(on)}$	$T_{vj} = 25^{\circ}\text{C}$, $V_{CC} = 400\text{V}$, $I_C = 50.0\text{A}$, $V_{GE} = 0.0/15.0\text{V}$, $R_{G(on)} = R_{G(off)} = 12\Omega$ Inductive load	-	15	-	ns
Rise time	t_r		-	33	-	
Turn-off delay time	$t_{d(off)}$		-	103	-	
Fall time	t_f		-	26	-	
Turn-on energy	E_{on}	Energy losses include “tail” and diode reverse recovery.	-	1.396	-	mJ
Turn-off energy	E_{off}		-	0.361	-	
Total switching energy	E_{ts}		-	1.758	-	
IGBT Characteristic, at $T_{vj} = 25^{\circ}\text{C}$						
Turn-on delay time	$t_{d(on)}$	$T_{vj} = 25^{\circ}\text{C}$, $V_{CC} = 400\text{V}$, $I_C = 25.0\text{A}$, $V_{GE} = 0.0/15.0\text{V}$, $R_{G(on)} = R_{G(off)} = 12\Omega$ Inductive load	-	13	-	ns
Rise time	t_r		-	13	-	
Turn-off delay time	$t_{d(off)}$		-	117	-	
Fall time	t_f		-	11	-	
Turn-on energy	E_{on}	Energy losses include “tail” and diode reverse recovery.	-	0.60	-	mJ
Turn-off energy	E_{off}		-	0.10	-	
Total switching energy	E_{ts}		-	0.70	-	
Diode Characteristic, at $T_{vj} = 25^{\circ}\text{C}$						
Diode reverse recovery time	t_{rr}	$T_{vj} = 25^{\circ}\text{C}$, $V_R = 400\text{V}$, $I_F = 50.0\text{A}$, $di_F/dt = 1000\text{A}/\mu\text{s}$	-	62	-	ns
Diode reverse recovery charge	Q_{rr}		-	1.15	-	μC
Diode peak reverse recovery current	I_{rrm}		-	30	-	A
Diode peak rate of fall of reverse Recovery current during t_b	di_{rr}/dt		-	4110	-	$\text{A}/\mu\text{s}$

Diode reverse recovery time	t_{rr}	$T_{vj} = 25^{\circ}\text{C}$, $V_R = 400\text{V}$, $I_F = 25.0\text{A}$, $di_F/dt = 1000\text{A}/\mu\text{s}$	-	48	-	ns
Diode reverse recovery charge	Q_{rr}		-	0.87	-	μC
Diode peak reverse recovery current	I_{rrm}		-	28	-	A
Diode peak rate of fall of reverse Recovery current during t_b	di_{rr}/dt		-	7600	-	A/ μs

Tab.7. Switching Characteristic (Inductive load)

Parameters	Symbol	Conditions	Min. value	Typ. value	Max. value	Unit
IGBT Characteristic, at $T_{vj} = 150^{\circ}\text{C}$						
Turn-on delay time	$t_{d(on)}$	$T_{vj} = 150^{\circ}\text{C}$, $V_{CC} = 400\text{V}$, $I_C = 50.0\text{A}$, $V_{GE} = 0.0/15.0\text{V}$, $R_{G(on)} = R_{G(off)} = 12\Omega$ Inductive load	-	16	-	ns
Rise time	t_r		-	33	-	
Turn-off delay time	$t_{d(off)}$		-	124	-	
Fall time	t_f		-	30	-	
Turn-on energy	E_{on}	Energy losses include "tail" and diode reverse recovery.	-	1.63	-	mJ
Turn-off energy	E_{off}		-	0.56	-	
Total switching energy	E_{ts}		-	2.19	-	
Turn-on delay time	$t_{d(on)}$	$T_{vj} = 150^{\circ}\text{C}$, $V_{CC} = 400\text{V}$, $I_C = 25.0\text{A}$, $V_{GE} = 0.0/15.0\text{V}$, $R_{G(on)} = R_{G(off)} = 12\Omega$ Inductive load	-	14	-	ns
Rise time	t_r		-	16	-	
Turn-off delay time	$t_{d(off)}$		-	145	-	
Fall time	t_f		-	22	-	
Turn-on energy	E_{on}	Energy losses include "tail" and diode reverse recovery.	-	0.71	-	mJ
Turn-off energy	E_{off}		-	0.18	-	
Total switching energy	E_{ts}		-	0.89	-	

Diode Characteristic, at $T_{vj} = 150^{\circ}\text{C}$						
Diode reverse recovery time	t_{rr}	$T_{vj} = 150^{\circ}\text{C},$ $V_R = 400\text{V},$ $I_F = 50.0\text{A},$ $di_F/dt = 1000\text{A}/\mu\text{s}$	-	133	-	ns
Diode reverse recovery charge	Q_{rr}		-	4.3	-	μC
Diode peak reverse recovery current	I_{rrm}		-	57	-	A
Diode peak rate of fall of reverse Recovery current during t_b	di_{rr}/dt		-	1200	-	$\text{A}/\mu\text{s}$
Diode reverse recovery time	t_{rr}	$T_{vj} = 150^{\circ}\text{C},$ $V_R = 400\text{V},$ $I_F = 25.0\text{A},$ $di_F/dt = 1000\text{A}/\mu\text{s}$	-	106	-	ns
Diode reverse recovery charge	Q_{rr}		-	3.3	-	μC
Diode peak reverse recovery current	I_{rrm}		-	55	-	A
Diode peak rate of fall of reverse Recovery current during t_b	di_{rr}/dt		-	2210	-	$\text{A}/\mu\text{s}$

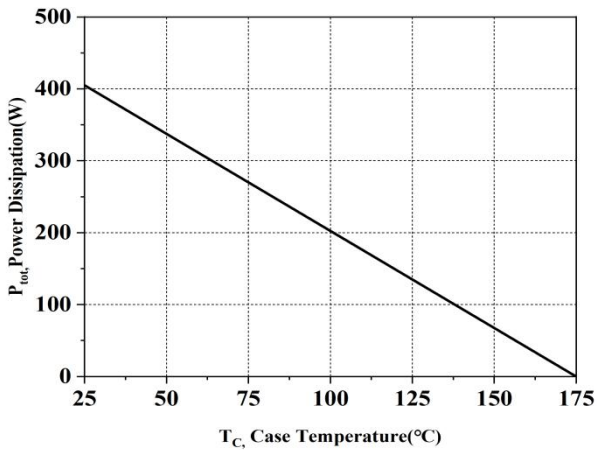

Fig.1. Power dissipation as a function of case temperature ($T_j \leq 175^\circ\text{C}$)

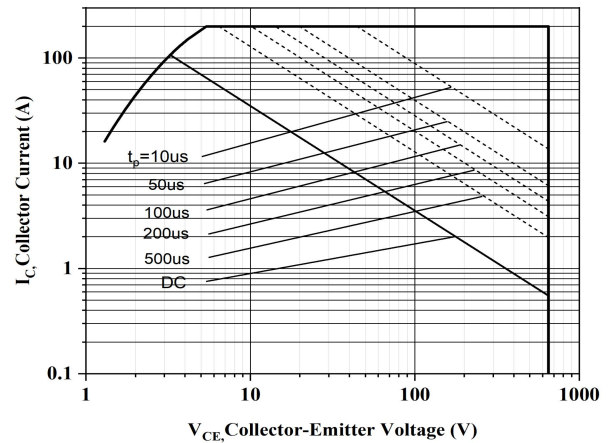

Fig.2. Forward bias safe operating area ($D = 0, T_C = 25^\circ\text{C}, T_j \leq 175^\circ\text{C}, V_{GE} = 15\text{V}$)

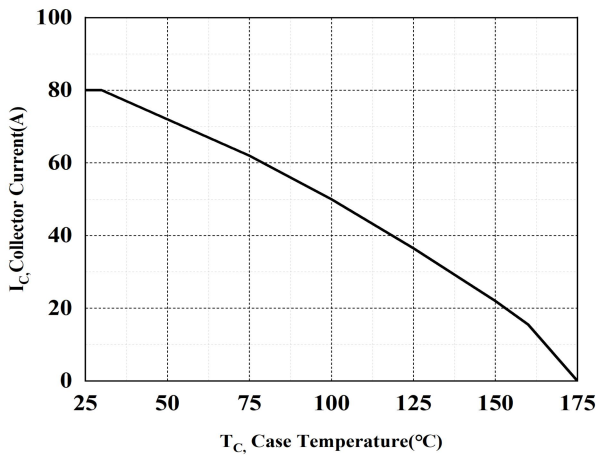

Fig.3. Collector current as a function of case temperature ($V_{GE} \geq 15\text{V}, T_j \leq 175^\circ\text{C}$)

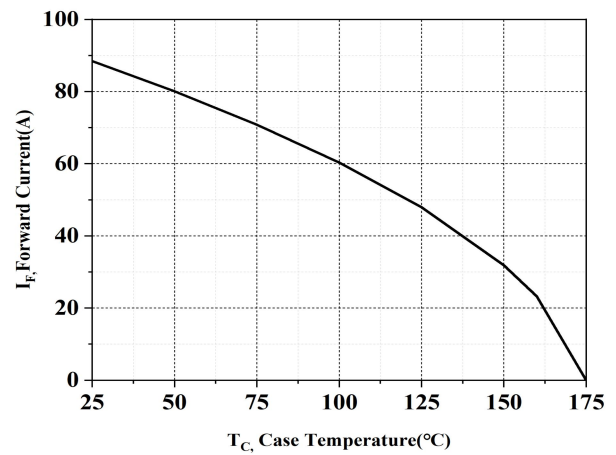

Fig.4. Diode Forward current as a function of case temperature ($T_j \leq 175^\circ\text{C}$)

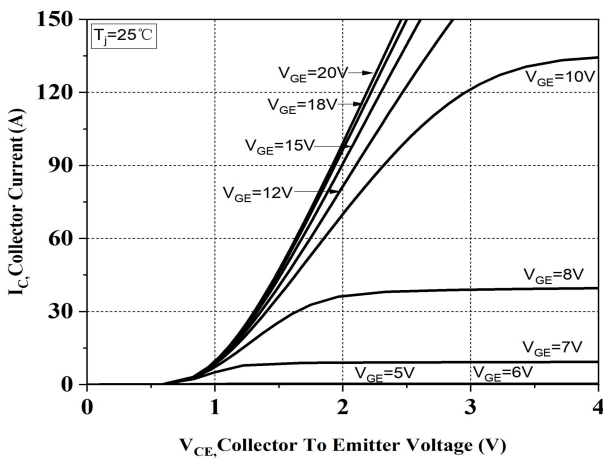

Fig.5. Typical output characteristics ($T_j = 25^\circ\text{C}$)

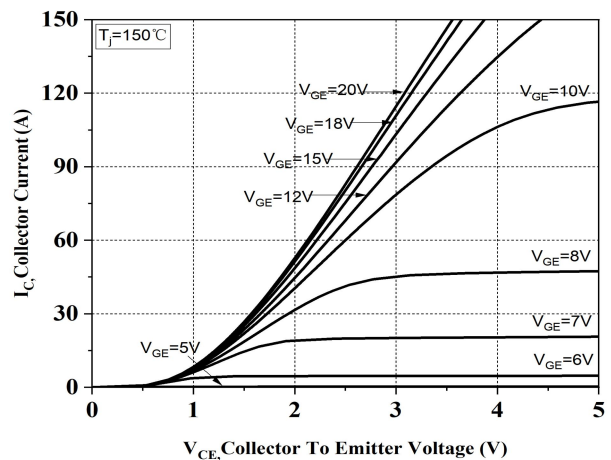

Fig.6. Typical output characteristics ($T_j = 150^\circ\text{C}$)

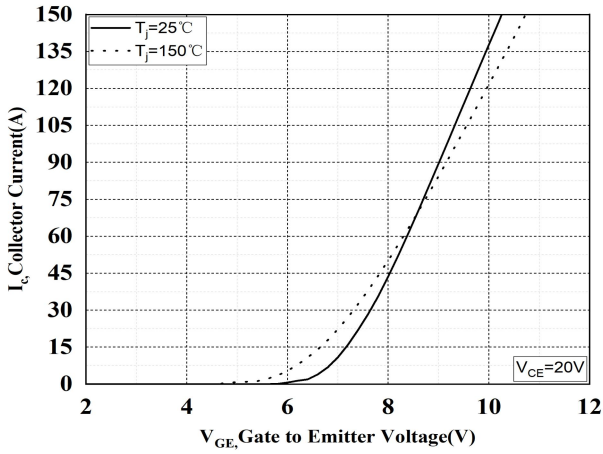

Fig.7. Typical transfer characteristic

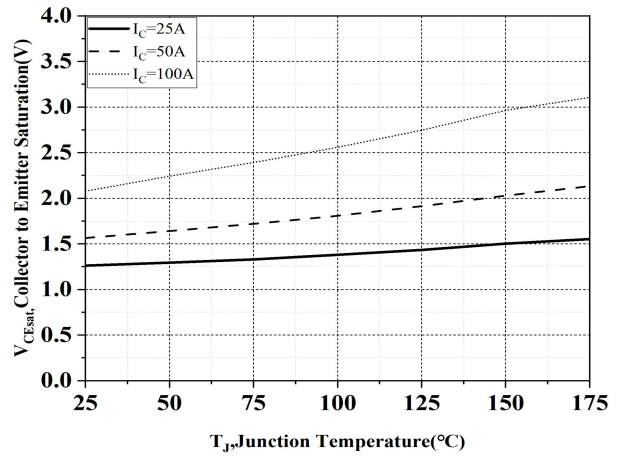

Fig.8. Typical collector-emitter saturation voltage vs. junction temperature ($V_{GE}=15\text{V}$)

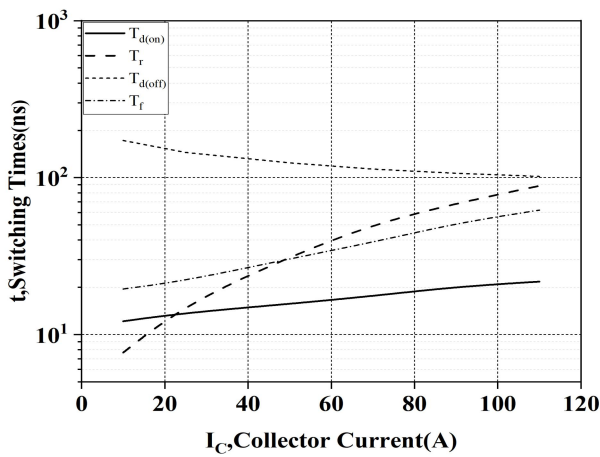

Fig.9. Typical switching times vs. collector current ($T_J=150^\circ\text{C}$, $V_{CE}=400\text{V}$, $V_{GE}=15/0\text{V}$)

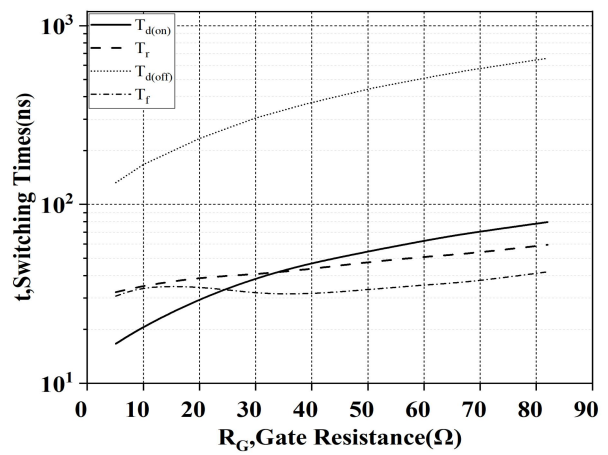

Fig.10. Typical switching times vs. gate Resistor

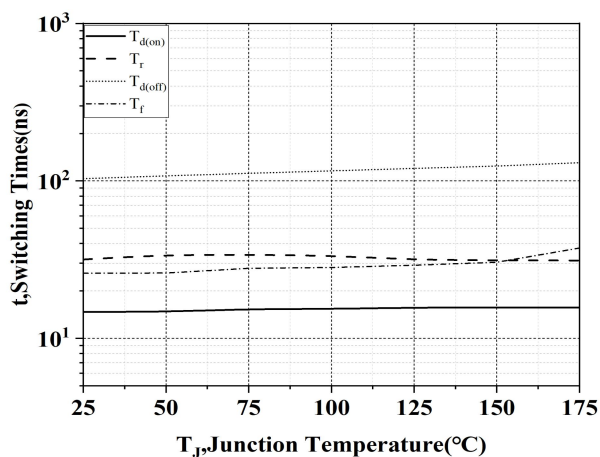

Fig.11. Typical switching times vs. junction temperature

($V_{CE}=400\text{V}$, $V_{GE}=15/0\text{V}$, $I_C=50\text{A}$)

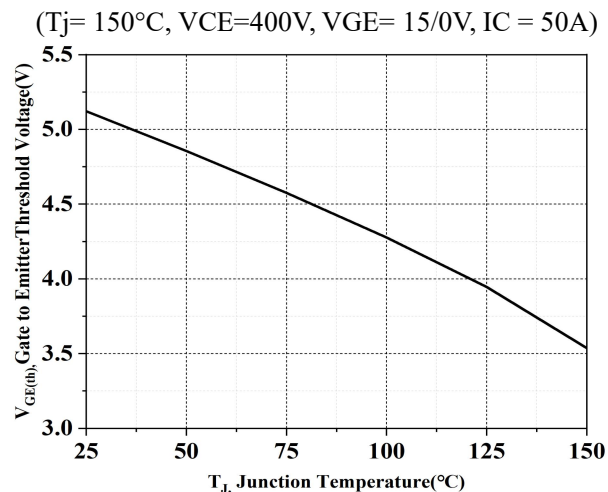

Fig.12. Gate-emitter threshold voltage vs. junction temperature

($I_C=0.5\text{mA}$)

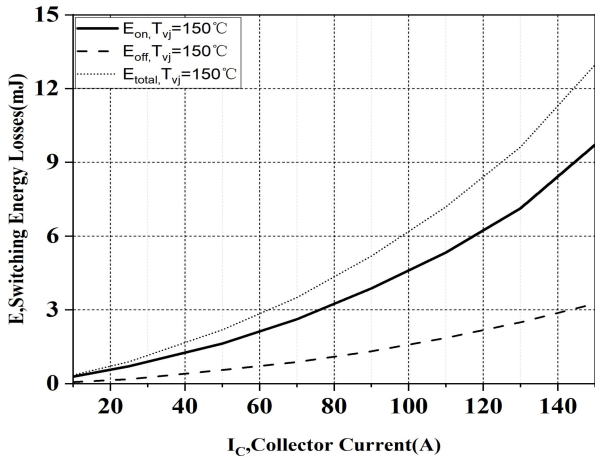

Fig.13. Typical switching energy losses as a function of collector current

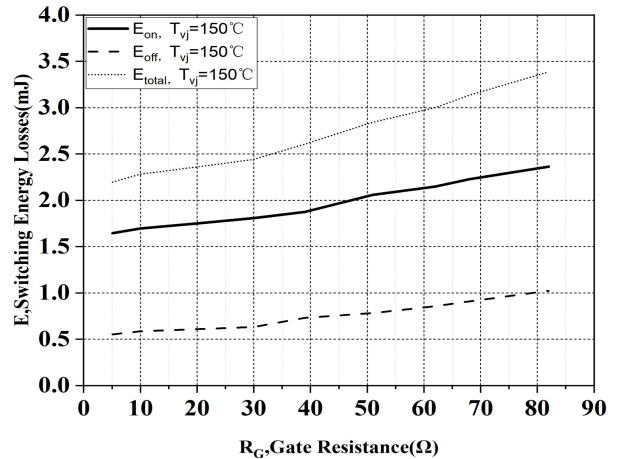

Fig.14. Typical switching energy losses as a function of gate resistor

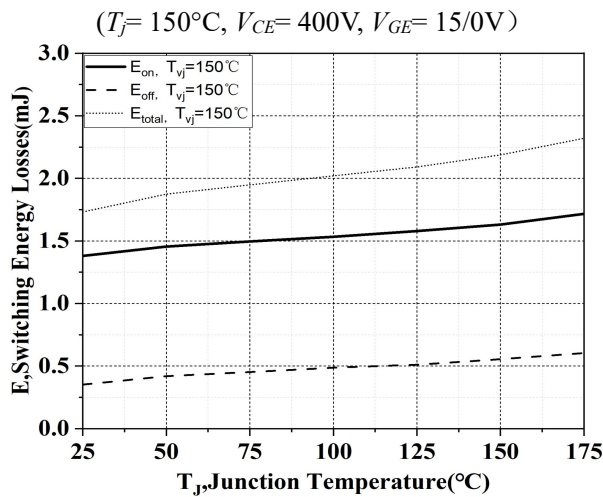

Fig.15. Typical switching energy losses as a function of junction temperature

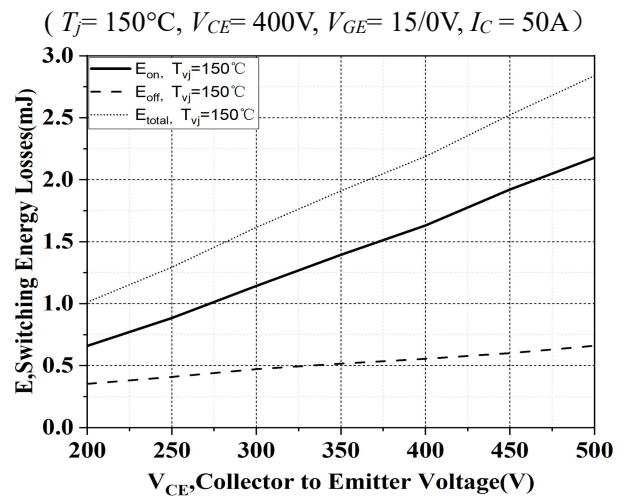

Fig.16. Typical switching energy losses as a function of collector emitter voltage

(Inductive load, $V_{CE} = 400\text{V}$, $V_{GE} = 15/0\text{V}$, $I_C = 50\text{A}$)

(Inductive load, $T_j = 150^\circ\text{C}$, $V_{GE} = 15/0\text{V}$, $I_C = 50\text{A}$)

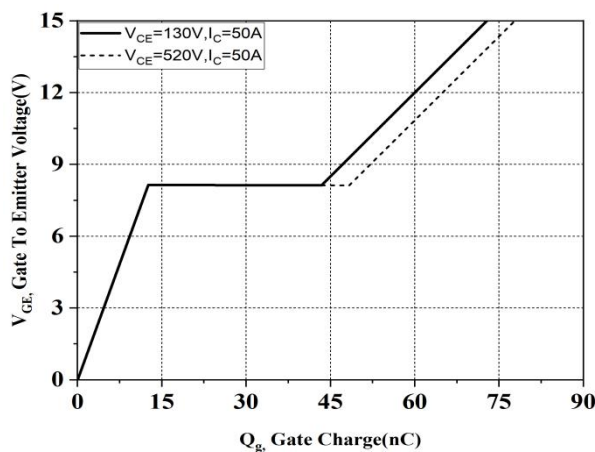

Fig.17. Typical gate charge

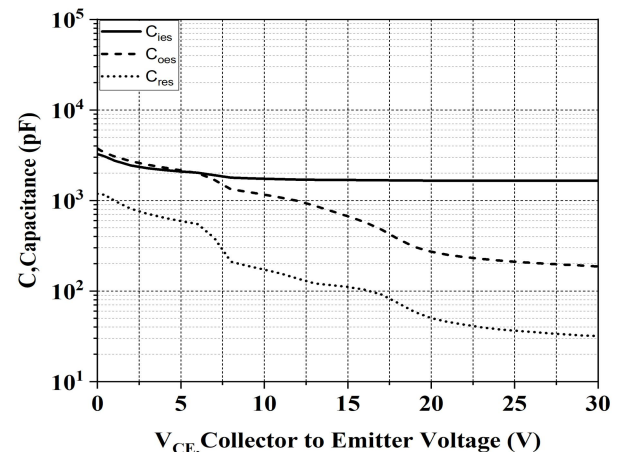

Fig.18. Typical capacitance as a function of collector-emitter voltage
($V_{GE} = 0\text{V}$, $f = 1\text{MHz}$)

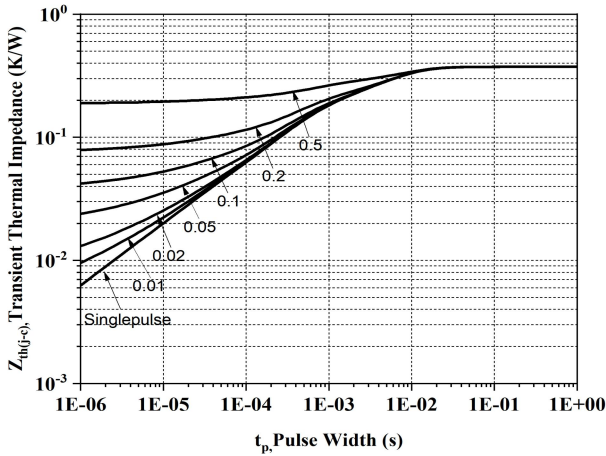

Fig.19. IGBT transient thermal impedance
($D = t_p/T$)

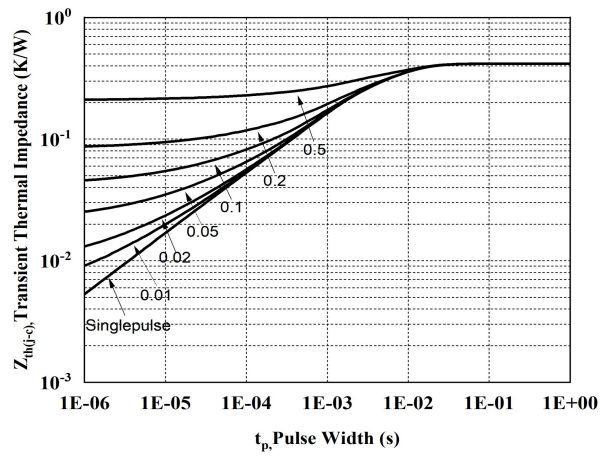

Fig.20. Transient thermal impedance of diode
($D = t_p/T$)

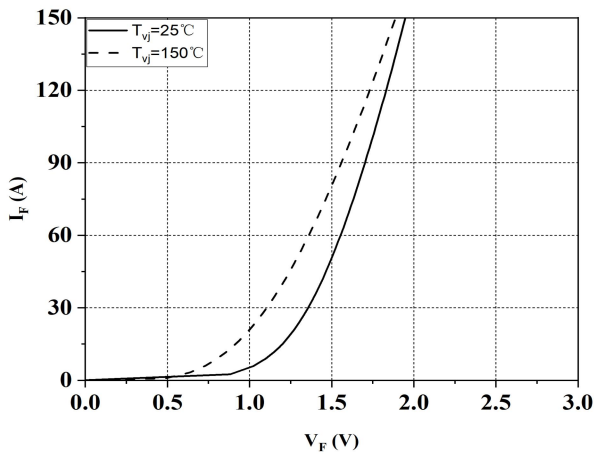

Fig.21. Typical diode forward current as a function of forward voltage

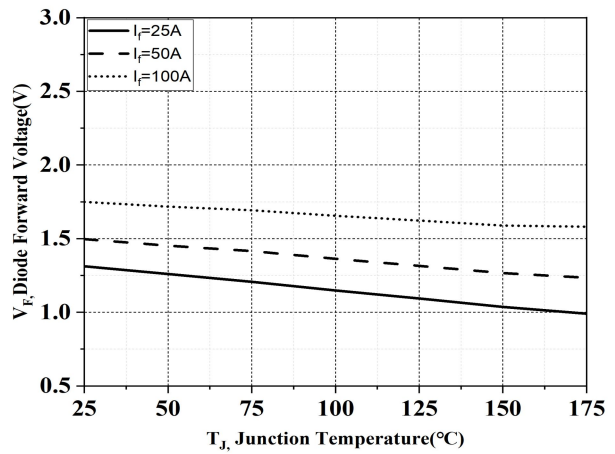

Fig.22. Typical diode forward voltage as a function of junction temperature

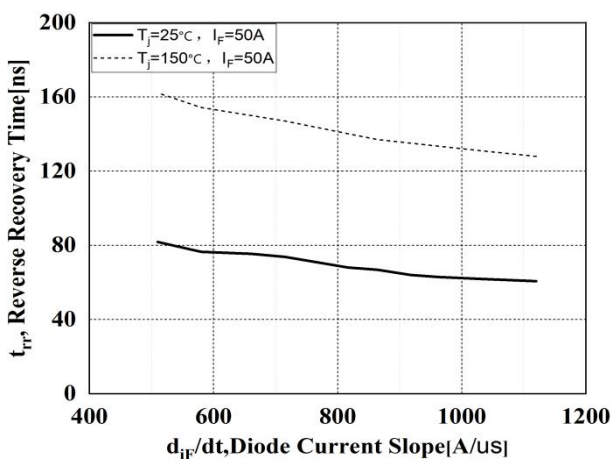

Fig.23. Typical reverse recovery time as a function of diode current slope
($VR=400V$)

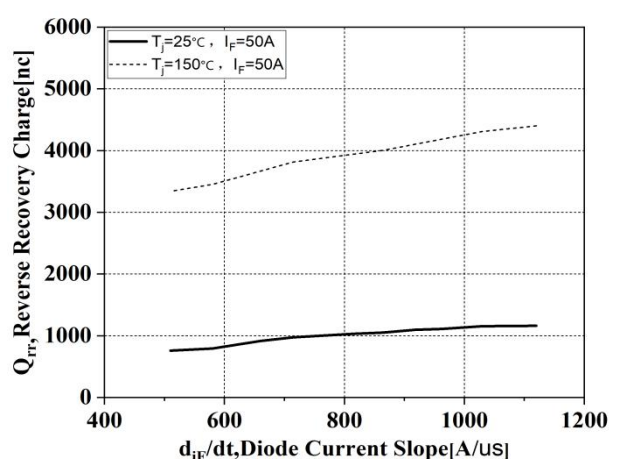

Fig.24. Typical reverse recovery charge as a function of diode current slope
($VR=400V$)

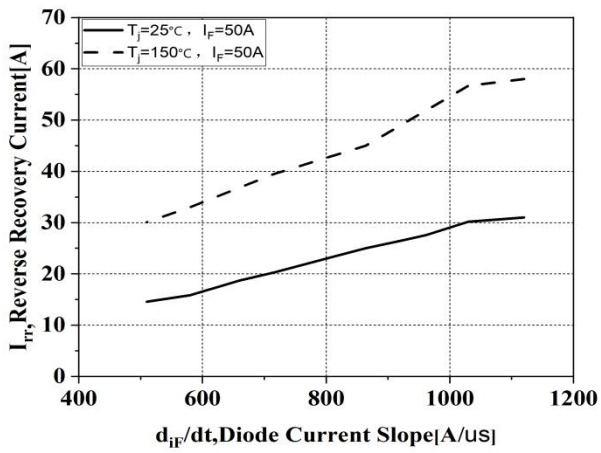

Fig.25. Typical reverse recovery current as a function of diode current slope (VR=400V)

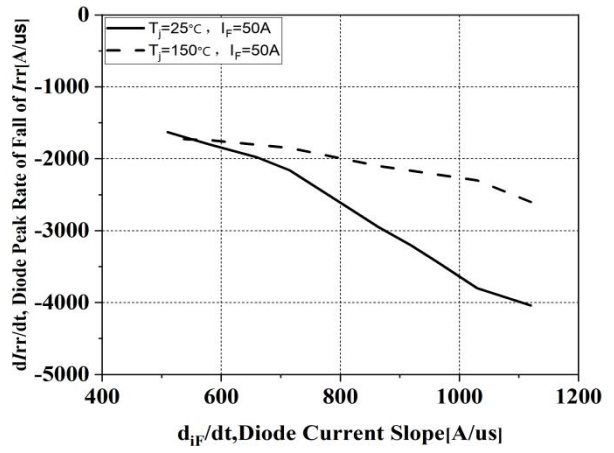
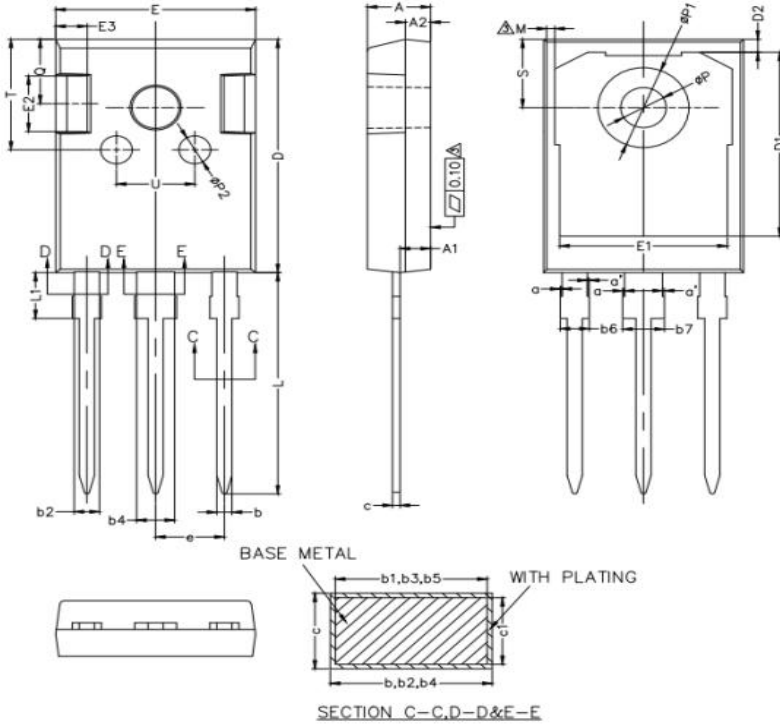

Fig.26. Typical diode peak rate of fall of reverse recovery current as a function of diode current slope (VR=400V)

7. Package Dimensions



COMMON DIMENSIONS
(UNITS OF MEASURE—MILLIMETER)

SYMBOL	MIN	NOM	MAX
A	4.90	5.00	5.10
A1	2.31	2.41	2.51
A2	1.90	2.00	2.10
a	0	—	0.15
a'	0	—	0.15
b	1.16	—	1.26
b1	1.15	1.2	1.22
b2	1.96	—	2.06
b3	1.95	2.00	2.02
b4	2.96	—	3.06
b5	2.95	3.00	3.02
b6	—	—	2.25
b7	—	—	3.25
c	0.59	—	0.66
c1	0.58	0.60	0.62
D	20.90	21.00	21.10
D1	16.25	16.55	16.85
D2	1.05	1.20	1.35
E	15.70	15.80	15.90
E1	13.10	13.30	13.50
E2	4.90	5.00	5.10
E3	2.40	2.50	2.60
e	5.34	5.44	5.54
L	19.80	19.92	20.10
L1	3.95	4.13	4.30
M	0.35	—	0.95
P	3.50	3.60	3.70
P1	7.00	—	7.40
P2	2.40	2.50	2.60
Q	5.60	—	6.00
S	6.05	6.15	6.25
T	9.80	—	10.20
U	6.00	—	6.40

NOTES:
1. ALL DIMENSIONS REFER TO JEDEC STANDARD TO-247 AD DO NOT INCLUDE MOLD FLASH OR PROTRUSIONS.
2. EJECTION MARK DEPTH 0.10 ± 0.05 .

8. Version Information

Version No.	Status	Date changed	Version revision record
V1.0	Preliminary version	2024/03	