



High-speed IGBT Power Transistor

(Integrated SiC SBD)

1. Product Features:

- Ultra-low switching losses
- Benchmark efficiency in hard switching topologies
- Plug-and-play replacement of pure Si-based IGBT
- Internal integrated SiC Schottky Diode (SBD)
- Maximum junction temperature 175°C
- Qualified according to JEDEC
- RoHS compliant

2. Product Applications

- Industrial Power Supplies
- Solar String Inverter
- Energy Storage Inverter
- UPS
- DC Charger for Electric Vehicles
- Welding Machines

HKZ75N65SHRA

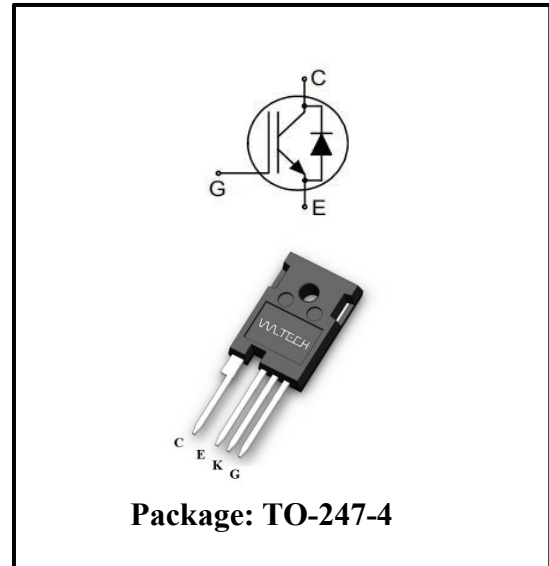

3. Typical Performance Parameters

Tab.1. Typical Performance Parameters

Type	V_{CE}	I_C	V_{CEsat}	T_{vjmax}	Marking	Package
HKZ75N65SHRA	650V	75A	1.66V ($T_{vj} = 25^\circ\text{C}$)	175°C	HKZ75N65SHRA	TO-247-4

4. Maximum Ratings

Tab.2. Maximum Ratings

Parameters	Symbol	Value	Unit
Collector-emitter voltage	V_{CE}	650	V
DC collector current (limited by T_{vjmax})	I_C	90($T_c = 25^\circ\text{C}$) 75($T_c = 100^\circ\text{C}$)	A
Pulsed collector current (t_p limited by T_{vjmax} .)	I_{Cpuls}	300	A
Diode forward current (limited by T_{vjmax})	I_F	52($T_c = 100^\circ\text{C}$)	A
Diode pulse current (t_p limited by T_{vjmax} .)	I_{Fpuls}	200($T_c = 25^\circ\text{C}$)	A
Gate-emitter voltage	V_{GE}	± 20	V
Transient Gate-emitter voltage ($t_p \leq 10\mu\text{s}$, $D < 0.0100$)		± 30	V
Power dissipation	P_{tot}	395($T_c = 25^\circ\text{C}$) 197($T_c = 100^\circ\text{C}$)	W
Operating junction temperature	T_{vj}	-40 to +175	$^\circ\text{C}$
Storage temperature	T_{stg}	-55 to +150	$^\circ\text{C}$
Soldering temperature, (wave soldering 1.6mm from case for 10s)		260	$^\circ\text{C}$
Mounting torque (M3 screw) (Maximum of mounting processes: 3)	M	0.6	Nm

5. Thermal Properties

Tab.3. Thermal Properties

Parameters	Symbol	Conditions	Max. value	Unit
IGBT thermal resistance (junction - case)	$R_{th(j-c)}$		0.38	$^\circ\text{C/W}$
Diode thermal resistance (junction - case)	$R_{th(j-c)}$		0.57	$^\circ\text{C/W}$
Thermal resistance (junction – ambient)	$R_{th(j-a)}$		40	$^\circ\text{C/W}$

6. Electrical Characteristics

Tab.4. Static Characteristic ($T_{vj} = 25^{\circ}\text{C}$, unless otherwise specified)

Parameters	Symbol	Conditions	Min. value	Typ. value	Max. value	Unit
Collector-emitter breakdown voltage	$V_{(BR)CES}$	$V_{GE} = 0\text{V}$	650	-	-	V
Collector-emitter saturation voltage	V_{CEsat}	$V_{GE} = 15\text{V}, I_C = 75\text{A}$ $T_{vj} = 25^{\circ}\text{C}$ $T_{vj} = 175^{\circ}\text{C}$	- -	1.66 2.12	2.3 -	V
Diode forward voltage	V_F	$V_{GE} = 0\text{V}, I_F = 30\text{A}$ $T_{vj} = 25^{\circ}\text{C}$ $T_{vj} = 175^{\circ}\text{C}$	- -	1.41 1.84	1.8 -	V
Gate-emitter threshold voltage	$V_{GE(th)}$	$I_C = 0.75\text{mA}, V_{CE} = V_{GE}$	4.2	5.2	6.2	V
Zero gate voltage collector current	I_{CES}	$V_{CE} = 650\text{V}, V_{GE} = 0\text{V}$ $T_{vj} = 25^{\circ}\text{C}$ $T_{vj} = 175^{\circ}\text{C}$	- -	1 800	75 -	μA
Gate-emitter leakage current	I_{GES}	$V_{CE} = 0\text{V}, V_{GE} = 20\text{V}$	-	-	100	nA
Transconductance	g_{fs}	$V_{CE} = 20\text{V}, I_C = 75.0\text{A}$	-	41.0	-	S

Tab.5. Dynamic Characteristic ($T_{vj} = 25^{\circ}\text{C}$, unless otherwise specified)

Parameters	Symbol	Conditions	Min. value	Typ. value	Max. value	Unit
Input capacitance	C_{ies}	$V_{CE} = 25\text{V}, V_{GE} = 0\text{V}$ $f = 250\text{kHz}$	-	2755	-	pF
Output capacitance	C_{oes}		-	527	-	
Reverse transfer capacitance	C_{res}		-	52	-	
Gate-charge	Q_g	$V_{CE} = 520\text{V}, I_C = 75.0\text{A},$ $V_{GE} = 15\text{V}$	-	92	-	nC

Tab.6. Switching Characteristic (Inductive load)

Parameters	Symbol	Conditions	Min. value	Typ. value	Max. value	Unit
IGBT Characteristic, at $T_{vj} = 25^{\circ}\text{C}$						
Turn-on delay time	$t_{d(on)}$	$T_{vj} = 25^{\circ}\text{C}$, $V_{CC} = 400\text{V}$, $I_C = 75.0\text{A}$, $V_{GE} = 0.0/15.0\text{V}$, $R_{G(on)} = 1.5\Omega$, $R_{G(off)} = 1.5\Omega$, $R_{G(int)} = 7.5\Omega$ Inductive load	-	26	-	ns
Rise time	t_r		-	30	-	
Turn-off delay time	$t_{d(off)}$		-	110	-	
Fall time	t_f		-	30	-	
Turn-on energy	E_{on}	Energy losses include “tail” and diode reverse recovery.	-	0.46	-	mJ
Turn-off energy	E_{off}		-	0.66	-	
Total switching energy	E_{ts}		-	1.12	-	
IGBT Characteristic, at $T_{vj} = 25^{\circ}\text{C}$						
Turn-on delay time	$t_{d(on)}$	$T_{vj} = 25^{\circ}\text{C}$, $V_{CC} = 400\text{V}$, $I_C = 37.5\text{A}$, $V_{GE} = 0.0/15.0\text{V}$, $R_{G(on)} = 1.5\Omega$, $R_{G(off)} = 1.5\Omega$, $R_{G(int)} = 7.5\Omega$ Inductive load	-	22	-	ns
Rise time	t_r		-	22	-	
Turn-off delay time	$t_{d(off)}$		-	120	-	
Fall time	t_f		-	46	-	
Turn-on energy	E_{on}	Energy losses include “tail” and diode reverse recovery.	-	0.29	-	mJ
Turn-off energy	E_{off}		-	0.28	-	
Total switching energy	E_{ts}		-	0.57	-	

Tab.7. Switching Characteristic (Inductive load)

Parameters	Symbol	Conditions	Min. value	Typ. value	Max. value	Unit
IGBT Characteristic, at $T_{vj} = 150^{\circ}\text{C}$						
Turn-on delay time	$t_{d(on)}$	$T_{vj} = 150^{\circ}\text{C}$, $V_{CC} = 400\text{V}$, $I_C = 75.0\text{A}$, $V_{GE} = 0.0/15.0\text{V}$, $R_{G(on)} = 1.5\Omega$, $R_{G(off)} = 1.5\Omega$, $R_{G(int)} = 7.5\Omega$ Inductive load	-	28	-	ns
Rise time	t_r		-	37	-	
Turn-off delay time	$t_{d(off)}$		-	143	-	
Fall time	t_f		-	49	-	
Turn-on energy	E_{on}	Energy losses include “tail” and diode reverse recovery.	-	0.68	-	mJ
Turn-off energy	E_{off}		-	1.1	-	
Total switching energy	E_{ts}		-	1.78	-	
IGBT Characteristic, at $T_{vj} = 150^{\circ}\text{C}$						
Turn-on delay time	$t_{d(on)}$	$T_{vj} = 150^{\circ}\text{C}$, $V_{CC} = 400\text{V}$, $I_C = 37.5\text{A}$, $V_{GE} = 0.0/15.0\text{V}$, $R_{G(on)} = 1.5\Omega$, $R_{G(off)} = 1.5\Omega$, $R_{G(int)} = 7.5\Omega$ Inductive load	-	23	-	ns
Rise time	t_r		-	27	-	
Turn-off delay time	$t_{d(off)}$		-	161	-	
Fall time	t_f		-	62	-	
Turn-on energy	E_{on}	Energy losses include “tail” and diode reverse recovery.	-	0.35	-	mJ
Turn-off energy	E_{off}		-	0.49	-	
Total switching energy	E_{ts}		-	0.84	-	

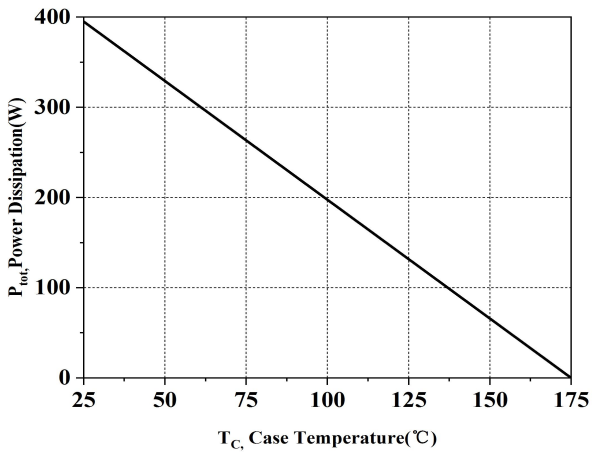

Fig.1. Power dissipation as a function of case temperature ($T_j \leq 175^\circ\text{C}$)

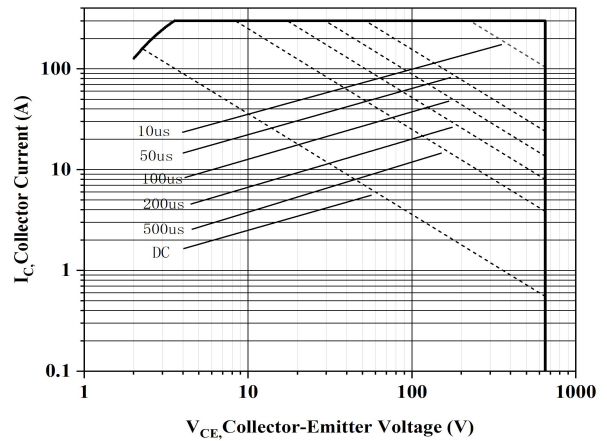

Fig.2. Forward bias safe operating area ($D = 0, T_C = 25^\circ\text{C}, T_j \leq 175^\circ\text{C}, V_{GE} = 15\text{V}$)

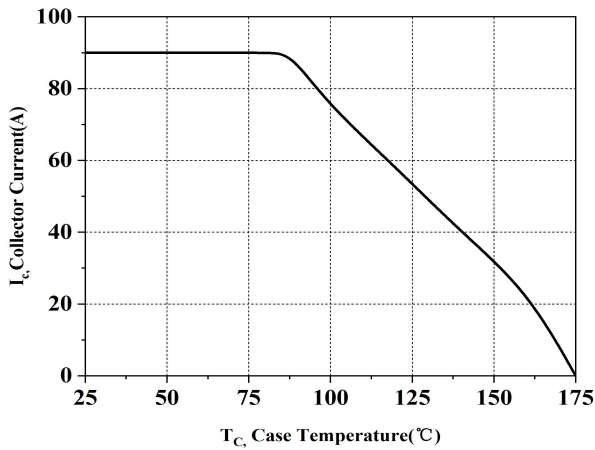

Fig.3. Collector current as a function of case temperature ($V_{GE} \geq 15\text{V}, T_j \leq 175^\circ\text{C}$)

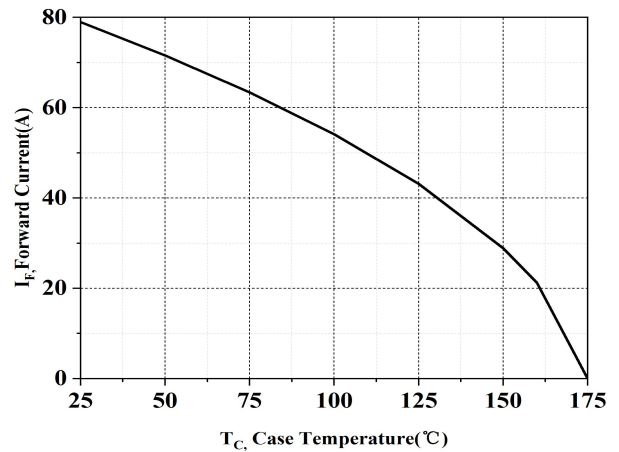

Fig.4. Diode Forward current as a function of case temperature

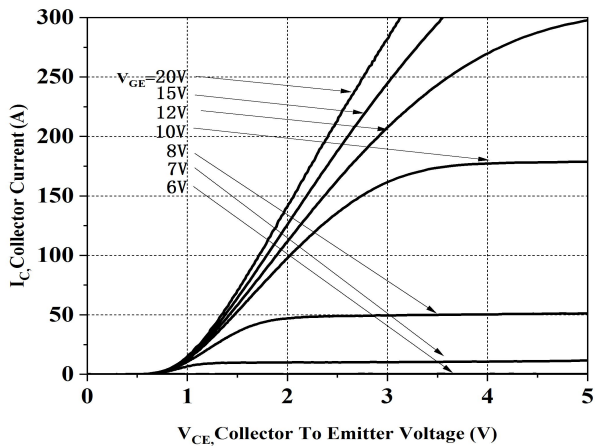

Fig.5. Typical output characteristics ($T_j = 25^\circ\text{C}$)

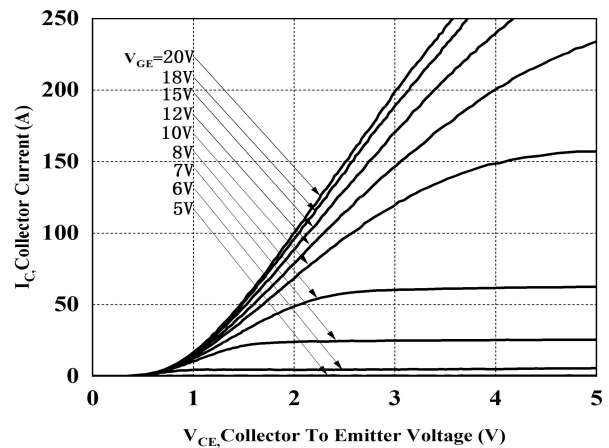

Fig.6. Typical output characteristics ($T_j = 150^\circ\text{C}$)

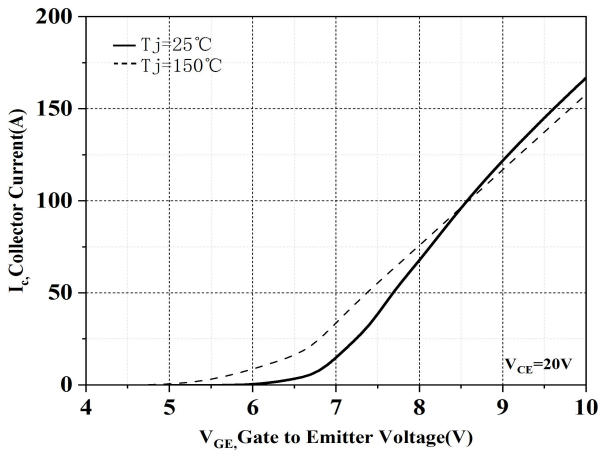

Fig.7. Typical transfer characteristic

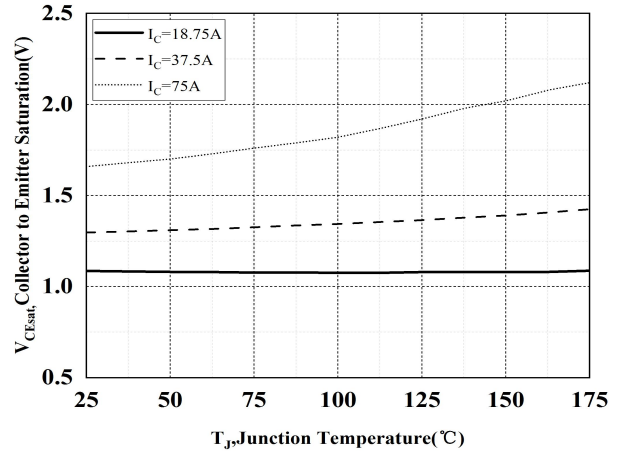

Fig.8. Typical collector-emitter saturation voltage as junction temperature ($V_{GE}=15V$)

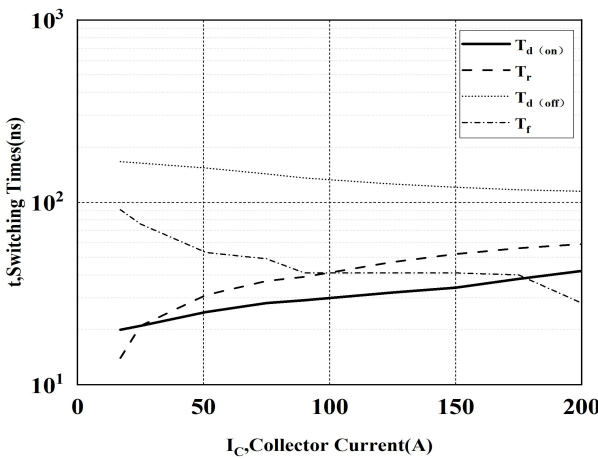

Fig.9. Typical switching times as collector current
($T_j = 150^\circ C, V_{CE} = 400V, V_{GE} = 15/0V$)

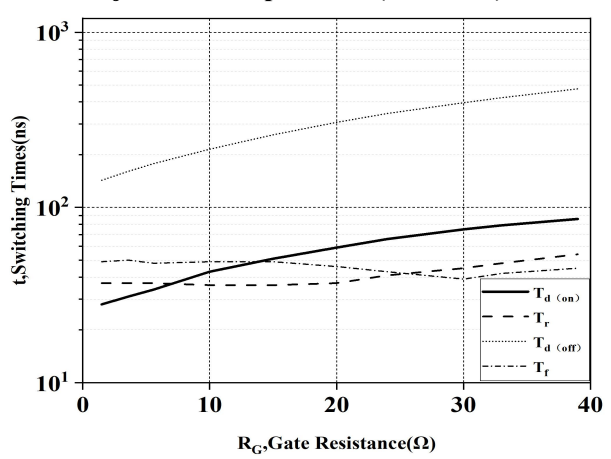

Fig.10. Typical switching times as gate Resistor
($T_j = 150^\circ C, V_{CE} = 400V, V_{GE} = 15/0V, I_C = 75A$)

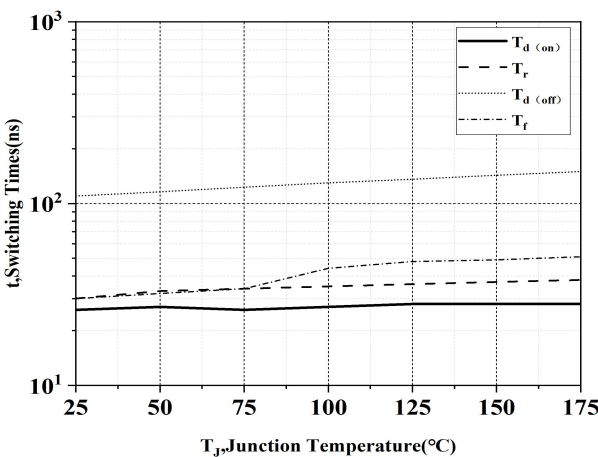

Fig.11. Typical switching times as junction temperature
($V_{CE} = 400V, V_{GE} = 15/0V, I_C = 75A$)

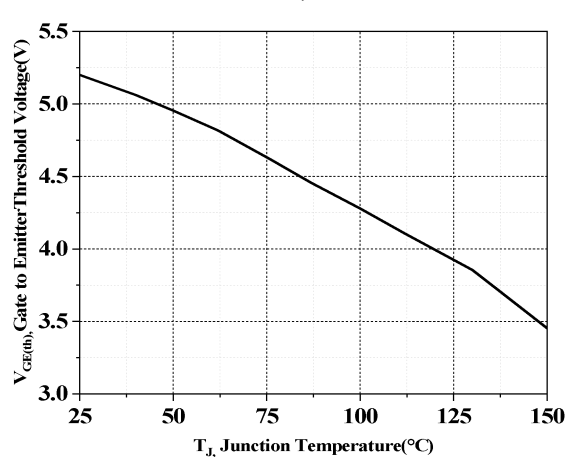

Fig.12. Gate-emitter threshold voltage as junction temperature
($I_C = 0.75mA$)

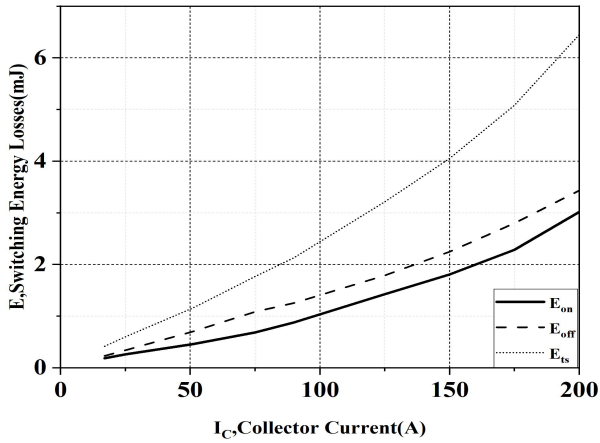

Fig.13. Typical switching energy losses as a function of collector current

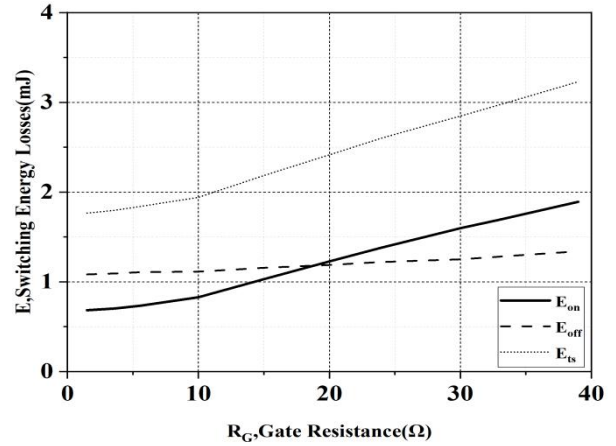

Fig.14. Typical switching energy losses as a function of gate resistor

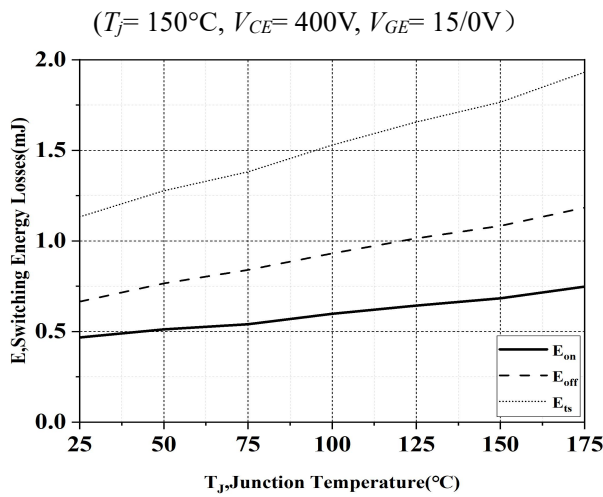

Fig.15. Typical switching energy losses as a function of junction temperature

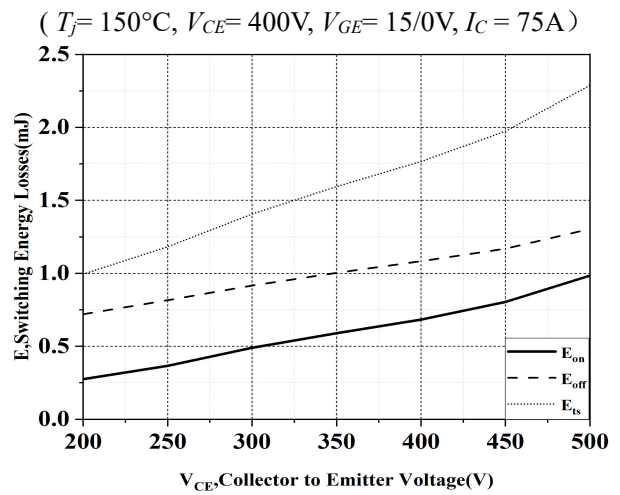

Fig.16. Typical switching energy losses as a function of collector emitter voltage

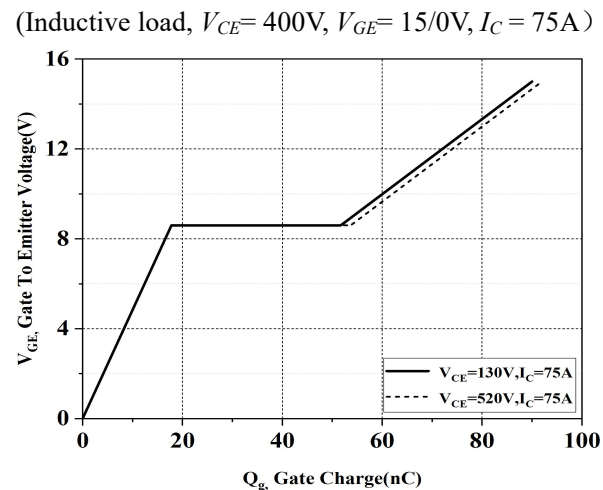

Fig.17. Typical gate charge

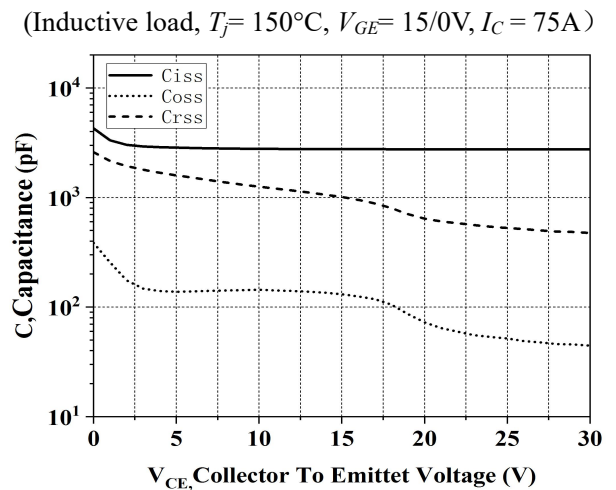

Fig.18. Typical capacitance as a function of collector-emitter voltage
($V_{GE} = 0\text{V}$, $f = 250\text{KHz}$)

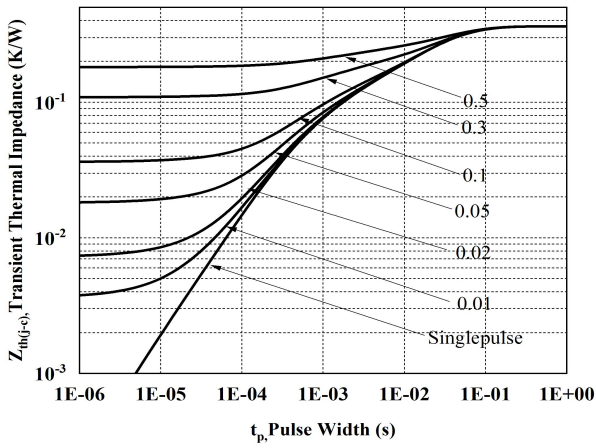

Fig.19. IGBT transient thermal impedance
($D = t_p/T$)

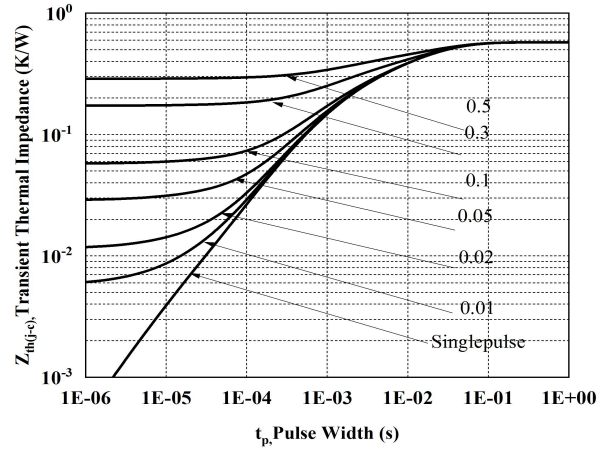

Fig.20. Transient thermal impedance of diode
($D = t_p/T$)

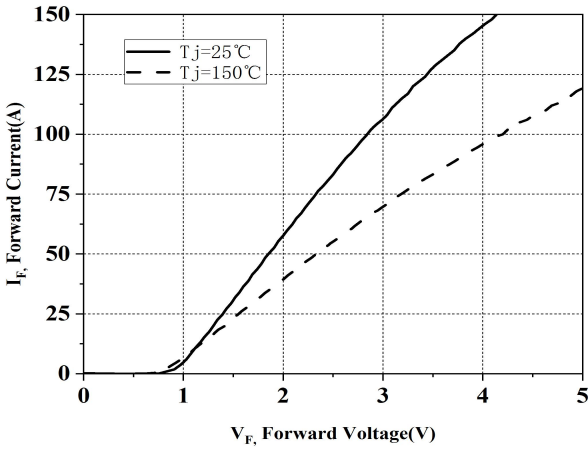

Fig.21. Typical diode forward current as a function of forward voltage

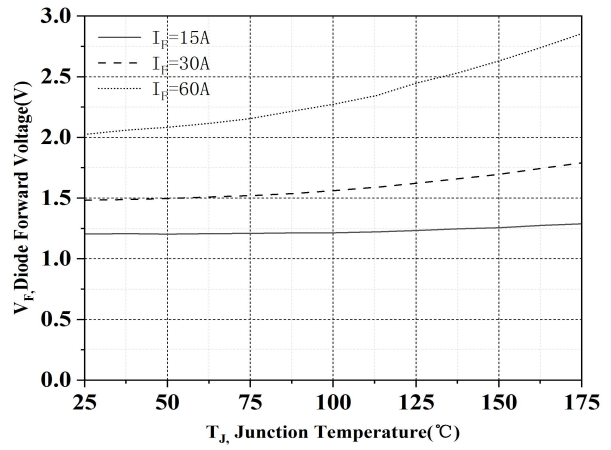
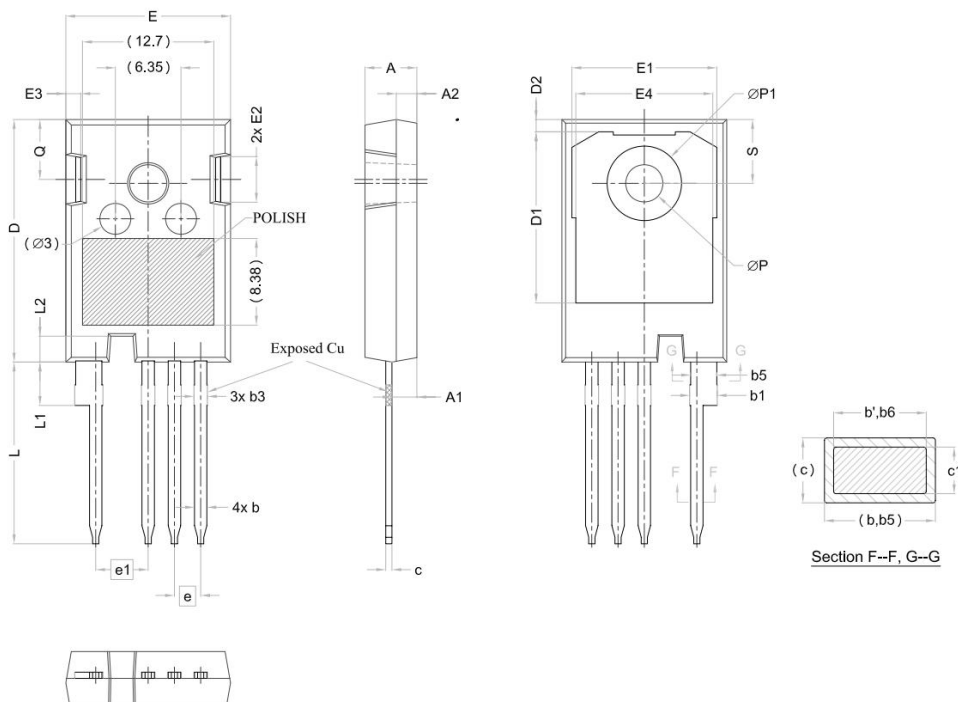

Fig.22. Typical diode forward voltage as a function of junction temperature

7. Package Dimensions



SYMBOL	DIMENSIONS		
	MIN.	NOM.	MAX.
A	4.83	5.02	5.21
A1	2.29	2.41	2.54
A2	1.91	2.00	2.16
b'	1.07	1.20	1.28
b	1.07	1.20	1.33
b1	2.39	2.67	2.94
b3	1.07	1.30	1.60
b5	2.39	2.53	2.69
b6	2.39	2.53	2.64
c	0.55	0.60	0.68
c1	0.55	0.60	0.65
D	23.30	23.45	23.60
D1	16.25	16.55	17.65
D2	0.95	1.19	1.25
E	15.75	15.94	16.13
E1	13.10	14.02	14.15
E2	3.68	4.40	5.10
E3	1.00	1.45	1.90
E4	12.38	13.26	13.43
e	2.54 BSC		
e1	5.08 BSC		
L	17.31	17.57	17.82
L1	3.97	4.19	4.37
L2	2.35	2.50	2.65
∅P	3.51	3.61	3.65
∅P1	7.19 REF.		
Q	5.49	5.79	6.00
S	6.04	6.17	6.30

8. Version Information

Version No.	Status	Date changed	Version revision record
V1.0	Initial release	2023/03	